



IN600 SERIES **THE PRACTICAL AND** **VERSATILE CHOICE** **FOR MOVING YOUR MAIL**

Optimize efficiency. Ensure quality.



HASLER

IN600 SERIES

OPTIMIZE EFFICIENCY. ENSURE QUALITY.

In today's fast paced business environments, we are always looking for ways to get the job done quickly and simply while maintaining integrity every step of the way. When it comes to your mail processing needs, the Hasler IN600 Series delivers practical solutions that offer maximum versatility. Available in two models, the IN600 HF and IN600 AF are built to move your mail with the highest level of efficiency.

At a first glance you will notice the contemporary design depicts clean lines, bold edges and aluminum accents, while maintaining the Hasler commitment to build and ship products in the most ecological manner. Coupled with the Hasler iMeter™ postage meter and a suite of Apps, the capabilities of the IN600 Series exceed those of traditional mailing systems.

With an iMeter™ postage meter, powerful Apps and a modern eco-friendly design, there is no doubt the IN600 Series is the practical and versatile choice for moving your mail today and in the future.



OPTIMIZING EFFICIENCY

The IN600 HF offers a power-assisted hand feeder/moistener combination and processes up to 75 lpm. All other components of the mailing system are shared with the IN600 AF system.

STAND OUT FROM THE REST

Personalize items and help promote your business with ad slogans, custom text messages, QR codes and company logos. All IN600 mailing systems print an IBI Lite indicia, optimizing ink yield and minimizing replenishment.



iMETER™ APPS
Monitor, track, confirm and save when processing items with the E-Services and E-Services with Electronic Return Receipt™ Apps.

INTEGRATED AUTOMATIC LABEL DISPENSER
Simplifies the processing of packages and large envelopes.

AUTOMATIC FEEDER AND SEALER
Processes items at speeds up to 110 lpm.

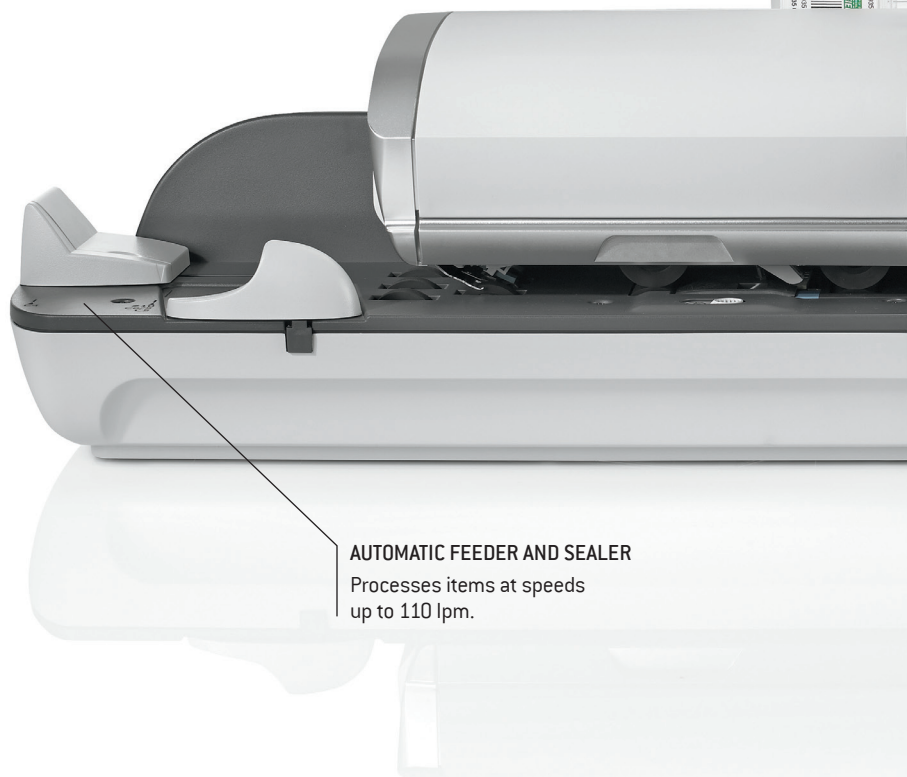

CLEAN MODERN SPACE-SAVING DESIGN
 HASLER iMETER™ POSTAGE METER AND BUSINESS APPS
 INTUITIVE CONTROL PANEL
 USER-FRIENDLY MAIL PROCESSING

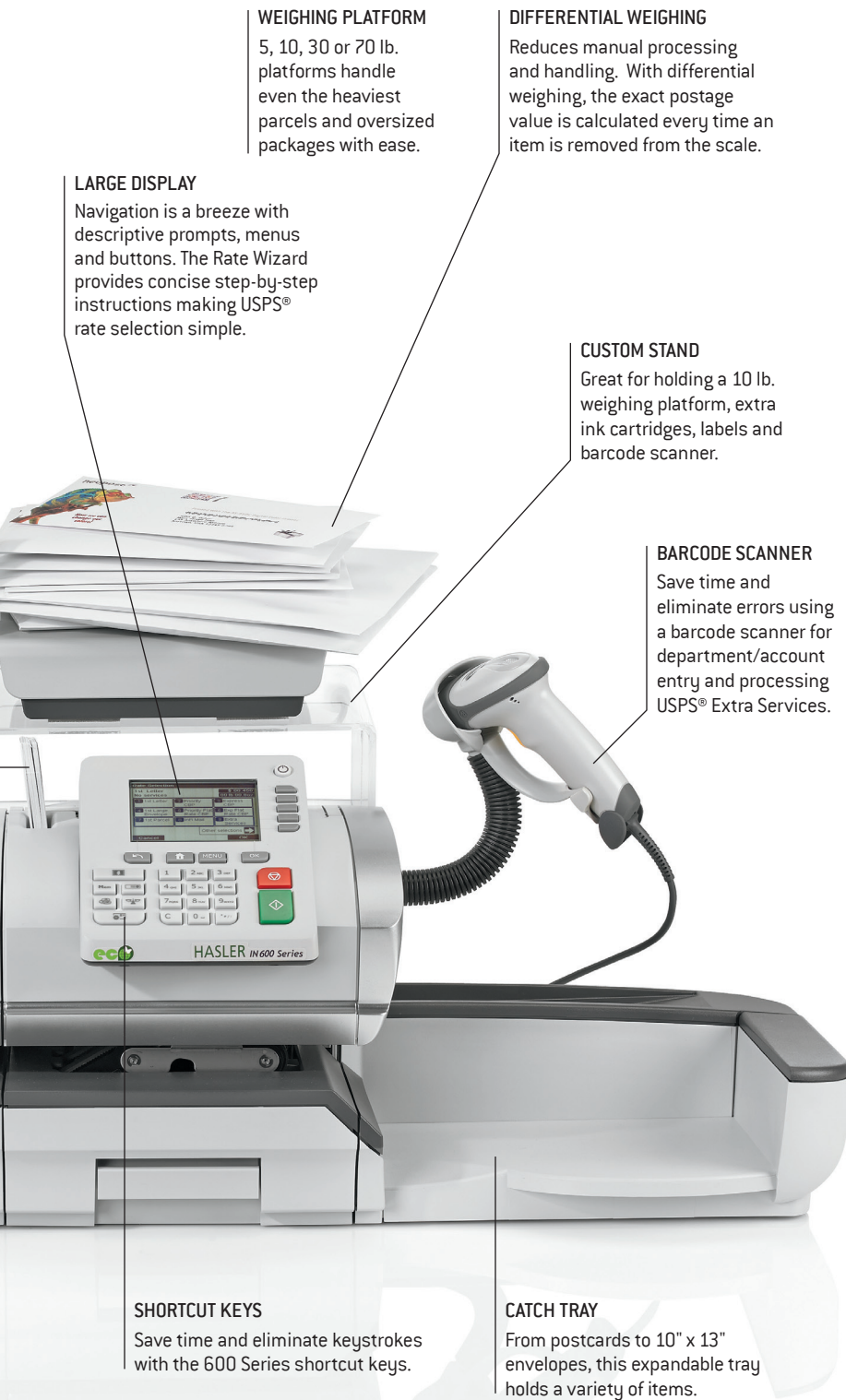

WEIGHING PLATFORM

5, 10, 30 or 70 lb. platforms handle even the heaviest parcels and oversized packages with ease.

DIFFERENTIAL WEIGHING

Reduces manual processing and handling. With differential weighing, the exact postage value is calculated every time an item is removed from the scale.

LARGE DISPLAY

Navigation is a breeze with descriptive prompts, menus and buttons. The Rate Wizard provides concise step-by-step instructions making USPS® rate selection simple.

CUSTOM STAND

Great for holding a 10 lb. weighing platform, extra ink cartridges, labels and barcode scanner.

BARCODE SCANNER

Save time and eliminate errors using a barcode scanner for department/account entry and processing USPS® Extra Services.

SHORTCUT KEYS

Save time and eliminate keystrokes with the 600 Series shortcut keys.

CATCH TRAY

From postcards to 10" x 13" envelopes, this expandable tray holds a variety of items.

HASLER iMETER™ POSTAGE METER AND BUSINESS APPS

The Hasler iMeter™ postage meter is an internet-connected smart device that provides functionality above the traditional postage meter. The IN600 Series and Hasler iMeter™ are connected online to help you better manage your mailing operations and control costs. Low ink email alerts keep you abreast of your ink usage and simplify ink cartridge reordering. With the IN600 Series, postal rate changes are hassle free with direct rate downloads, which ensure full postal compliance.

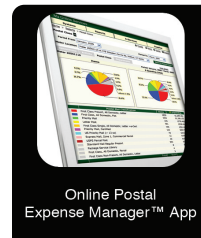

POSTAGE EXPENSE MANAGEMENT APP – YOUR KEY TO SAVINGS

Maximize control of your postage expenses! From basic to enhanced reporting, the IN600 Series offers a host of expandable Apps to meet the needs of your business. The Online Postal Expense Manager™ App provides postage usage trends by department, time period and postal class, which help with budget planning. Create spreadsheets and colorful graphs in just minutes, or export postage usage data to Excel for additional analysis and reporting.

The Hasler Postal Accountant App delivers the detailed reports you need to track, analyze, allocate, forecast and consolidate your mail processing activity. Automatic alerts and the ability to set budget limits help you monitor costs and control overspending. Postage usage data can be viewed and reported on for a single location or integrated multi-site enterprise.

Available iMeter™ Apps

- Postal Rates App
- Online Postal Expense Manager™ App
- Hasler Postal Accountant App
- Commercial Rates App
- E-Services App
- E-Services with Electronic Return Receipt™ App
- TotalFunds™ App

IN600 AF shown with optional 10 lb. weighing platform, custom stand and barcode scanner.

IN600 SERIES

OPTIMIZE EFFICIENCY.

ENSURE QUALITY.



DESIGNING THE MOST ECOLOGICAL SOLUTIONS

Hasler is dedicated to improving the sustainability of its activities and the environmental performance of its products at each stage of the lifecycle. The Eco label reflects our desire to make customers aware of the environmental progress we have made in recent years. A sticker is placed on all models that meet Hasler's environmental requirements.

The Eco label indicates implementation of key concepts to reduce or eliminate impact on the environment. This includes the use of environmentally sensitive materials, choice of raw materials, weight reduction, packaging, energy savings, lifecycle extension and end-of-life management. The Eco label aims to provide a clear and consistent set of environmental performance criteria for Hasler products, in order to recognize efforts made during the design phase.

The IN600 Series carries Hasler's Eco label ensuring our commitment to the environment.



RAW MATERIAL: We limit the weight and number of materials used when producing our solutions (44% less material and 10.5% fewer components than previous generation mailing systems).



PACKAGING: We reduce the volume of our packaging and use only cardboard which is fully recyclable.



ENERGY: The energy consumption of our products has been reduced with the IN600 Series standard "sleep mode" feature. In addition, we offer remote support whenever possible to reduce travel-related energy use.

SPECIFICATIONS	IN600 HF	IN600 AF
OPERATIONAL EFFICIENCY		
Processing speed	Up to 75 lpm	Up to 110 lpm
Feeding capability	Semi-automatic hand feed	Automatic feed
Envelope minimum/maximum	3.5" x 5"/10" x 13"	
Envelope thickness	Up to 1/2"	
Envelope orientation	Landscape or portrait	
Default rate setting	Yes	
Postage meter tapes	Yes	
Rate Wizard	Yes	
Rate shortcut keys	6	
Job / Imprint memories	9	
MAIL QUALITY AND SECURITY		
Advertising slogans	9 Standard/1 open	
QR codes	Yes	
Personalized text messages	10 Custom	
Postal mail class inscriptions	Automatic	
Incoming mail date stamp	Yes	
4-digit PIN code	50	
BUDGET OPTIMIZATION		
Account tracking	35 Depts. standard 100 and 300 depts. optional Optional – up to 10,000 depts.	
Hasler Postal Accountant App	Yes	
Commercial Rates App	Yes	
TotalFunds™ App	Yes	
ONLINE MANAGEMENT		
Method for postage refilling, rate and software updates	Internet standard; analog modem optional	
Online postage usage reporting	Yes	
Enhanced online reporting	Optional	
E-Services App	Optional	
E-Services with Electronic Return Receipt™ App	Optional	
Low ink email alerts	Yes	
PERIPHERALS		
Weighing platforms	Optional 5, 10, 30 or 70 lb.	
Differential weighing	Optional	
Barcode scanner	Optional	
USB memory key	Optional	
External USB report printer	Optional	
SYSTEM DIMENSIONS		
	(L x D x H)	
Mailing system (IN600 HF)	16" x 15" x 12"	
Mailing system with envelope tray (IN600 HF)	33" x 15" x 12"	
Mailing system (IN600 AF)	34" x 15" x 12"	
Mailing system with envelope tray (IN600 AF)	50" x 15" x 12"	

Neopost SA is a world leader in mailing and logistics solutions. Our innovative solutions bring simplicity and efficiency to your mailing process to make your business run better. Neopost brilliantbasics benefits provide excellence in all our offers, from products to support and services. They bring you the best in operational efficiency, mail quality and security, budget optimization and online management. Whether for advice or support, you enjoy our commitment to supply first-class service – on the phone, on site, or online. Benefit from immediate response times and remote diagnosis at our call centers and fast dispatch of service engineers when needed.

neopost  **USA** 1-888-NEOPOST (636-7678) www.neopostusa.com

Neopost® and the Neopost logo are registered trademarks of Neopost S.A. Hasler® is a registered trademark of Neopost USA Inc. All other company and product names may be trademarks and are the property of their respective owners. All information in this document, including descriptions of features, functions, performance and specifications is subject to change without written notice at any time.

USPS®, Express Mail®, Priority Mail®, eDelivery Confirmation™, eSignature Confirmation™, the Delivery Confirmation™ label, the Signature Confirmation™ label, eCertified Mail™, and Electronic Return Receipt™ are among the many trademarks of the U.S. Postal Service.

©2013 Neopost USA Inc. All Rights Reserved.
H066-1 6/13
2.5M



EAGLE Registrations Inc.
SERVICE • INTEGRITY • VALUE
ISO 14001 and OHSAS 18001
Registered by EAGLE Registrations Inc.